

OPÉRA-COMIQUE en 3 Actes

# LA FILLEULE DU ROI

Musique de A. VOGEL



Quadrille pour PIANO par

# ARBAN

à 2 Mains 5f  
à 4 Mains 6f

PARIS  
ENOCH PÈRE & FILS  
27, Boulev. des Italiens.

LONDON  
ENOCH & SONS  
19, Holles Street.

Limp. Frouy, Paris.

*à 2 Mains 5f*  
*à 4 Mains 6f*  
*Madrid 23/4*  
*11. adria 96/97*  
*Genio de 1875*  
*Bernareggi*

# LA FILLEULE DU ROI

## QUADRILLE.

OPÉRA - COMIQUE EN 3 ACTES DE A. VOGEL.



Par ARBAN.

N<sup>o</sup> 1.

PANTALON.

CHŒUR DES CUISINIERS.

CODA.

FIN. DUO. «Où, j'ai lu dans ton cœur»

D.C.

DUO. «Voici l'instant ma fille»

NO 2.  
ÉTÉ.

*f*

This musical score is for a duo in 2/4 time, marked 'NO 2.' and 'ÉTÉ.'. It features a treble and bass clef with a key signature of one sharp (F#). The melody in the treble clef is characterized by a series of eighth-note runs. The bass clef provides a steady accompaniment of chords. A dynamic marking of *f* (forte) is present at the beginning. The piece concludes with a double bar line and a repeat sign.

COUPLETS. «Ne me parlez pas des gens qui font de l'embarras»

*mf* *sf* *p*

This musical score is for 'COUPLETS' in 2/4 time, marked '«Ne me parlez pas des gens qui font de l'embarras»'. It features a treble and bass clef with a key signature of one sharp (F#). The melody in the treble clef consists of quarter and eighth notes. The bass clef accompaniment uses chords. Dynamic markings include *mf* (mezzo-forte), *sf* (sforzando), and *p* (piano). The piece ends with a double bar line and a repeat sign.

*mf* *sf* *f* *f*

This musical score continues the 'COUPLETS' section. It features a treble and bass clef with a key signature of one sharp (F#). The melody in the treble clef continues with quarter and eighth notes. The bass clef accompaniment uses chords. Dynamic markings include *mf* (mezzo-forte), *sf* (sforzando), and *f* (forte). The piece concludes with a double bar line, a repeat sign, and the marking 'D.C.' (Da Capo).

RONDE. «La Jeanneton pour dot n'aura dit-on»

N<sup>o</sup> 3.

POULE.

Musical notation for the first system of 'POULE.' in 6/8 time, marked *f*. The piece begins with a treble clef and a key signature of one flat. The melody is in the right hand, and the accompaniment is in the left hand, consisting of chords and eighth notes.Musical notation for the second system of 'POULE.' in 6/8 time, marked *p*. The melody continues in the right hand, and the accompaniment in the left hand features a more active eighth-note pattern.

CODA.

Musical notation for the CODA section of 'POULE.' in 6/8 time, marked *f*. The melody in the right hand concludes with a final cadence, while the left hand continues with a rhythmic accompaniment.

FIN. DUO. «Elle avait même une servante»

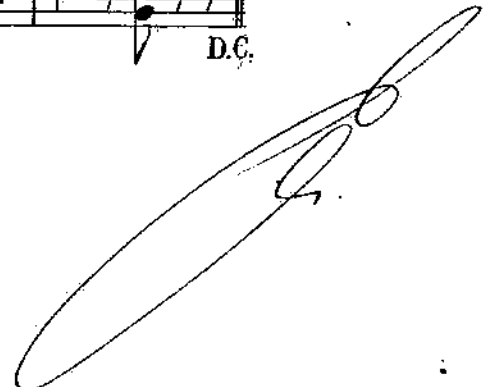
Musical notation for the DUO section of 'Elle avait même une servante' in 6/8 time, marked *f*. The piece starts with a double bar line and a repeat sign. The melody in the right hand is more melodic, and the left hand provides a steady accompaniment. The section ends with a final cadence and a *f* dynamic marking.

№ 4.

PASTOURELLE.

« Ehl zon, zin, zin, musettes »

The first system of the Pastourelle consists of two staves. The treble staff begins with a treble clef, a key signature of one sharp (F#), and a 2/4 time signature. The music starts with a forte (f) dynamic. The melody is characterized by eighth-note patterns and includes several accents (^) and trills (tr). The bass staff provides a rhythmic accompaniment with chords and eighth-note figures.

DANSES DU 4<sup>or</sup> ACTE.  
brillante.

The second system of the Danse du 4<sup>or</sup> Acte consists of two staves. The treble staff begins with a treble clef, a key signature of one sharp (F#), and a 2/4 time signature. The music starts with a mezzo-forte (mf) dynamic. The melody is characterized by eighth-note patterns and includes several trills (tr). The bass staff provides a rhythmic accompaniment with chords and eighth-note figures.

The third system of the Danse du 4<sup>or</sup> Acte consists of two staves. The treble staff begins with a treble clef, a key signature of one sharp (F#), and a 2/4 time signature. The music continues with a mezzo-forte (mf) dynamic. The melody is characterized by eighth-note patterns and includes several trills (tr). The bass staff provides a rhythmic accompaniment with chords and eighth-note figures. A key signature change to two sharps (F#, C#) is indicated by a sharp sign over the treble staff.

The fourth system of the Danse du 4<sup>or</sup> Acte consists of two staves. The treble staff begins with a treble clef, a key signature of two sharps (F#, C#), and a 2/4 time signature. The music continues with a mezzo-forte (mf) dynamic. The melody is characterized by eighth-note patterns and includes several trills (tr). The bass staff provides a rhythmic accompaniment with chords and eighth-note figures. The system ends with a forte (f) dynamic marking and a double bar line.

Leggiero. FINAL DU 1<sup>er</sup> ACTE.

№ 5.

FINAL.

Musical notation for the first system, featuring a treble and bass clef. The piece is in 2/4 time with a key signature of one sharp (F#). It begins with a piano (*p*) dynamic and includes a *crescendo* marking leading to a fortissimo (*ff*) dynamic.

1<sup>re</sup> et 3<sup>e</sup> Fois.

Musical notation for the second system, featuring a treble and bass clef. It begins with a fortissimo (*ff*) dynamic and includes a piano (*p*) marking.

Musical notation for the third system, featuring a treble and bass clef. It includes various dynamics and articulation marks such as accents (^) and slurs.

CHANSON DE LA GARBURE.

2<sup>e</sup> et 4<sup>e</sup> Fois.

Musical notation for the fourth system, featuring a treble and bass clef. It includes piano (*p*) and fortissimo (*f*) markings, as well as a *D.C.* (Da Capo) instruction.

Musical notation for the fifth system, featuring a treble and bass clef. It includes piano (*p*) and fortissimo (*f*) markings, as well as a *D.C.* (Da Capo) instruction.



D.C.